

F3 Straight Male Connectors

Scope of Use / Specification Sheet

SharkBite® plumbing fittings and pipe are manufactured in Australia at RWC's state of the art facilities. Stringent quality control and advanced manufacturing procedures guarantee product satisfaction.

SharkBite® is an advanced design push-to-connect plumbing system for potable water distribution. SharkBite® is available in an assortment of over 200 fittings and PEX pipe ranging from 16-25mm size. SharkBite® has been engineered with ease of use and disconnection in mind and while being the most dependable way to join copper and PEX Pipe in any combination – with no soldering, clamps, unions or glue.

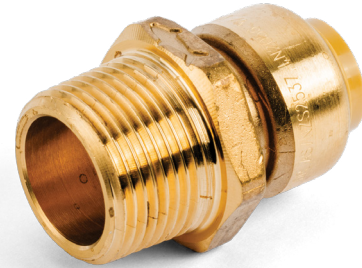

F116X

Features and Benefits

- Quick and easy to install in both wet or dry conditions
- No expensive tools required - supplied ready for installation
- Approved for behind the wall application
- Approved for underground installation with SharkBite® Silicone Wrap (F708)
- Instant push-to-connect connection. Cut. Push. Done.
- Removable after installation
- Integral tube liner for PEX installations means no loose components and ensures a secure reliable connection

Product List

Order Code	Description
F116X	16mm x 1/2" MI
F120X	16mm x 3/4" MI
F134X	20mm x 3/4" MI
F138X	20mm x 1/2" MI
F140X	25mm (25Cu) x 1" MI
F142X	25mm (25Cu) x 3/4" MI

Materials

Body	LF DZR Brass
Grab Ring	316 Stainless Steel
O-Ring	EPDM
Tube Liner	Polysulfone (PEX fittings only)

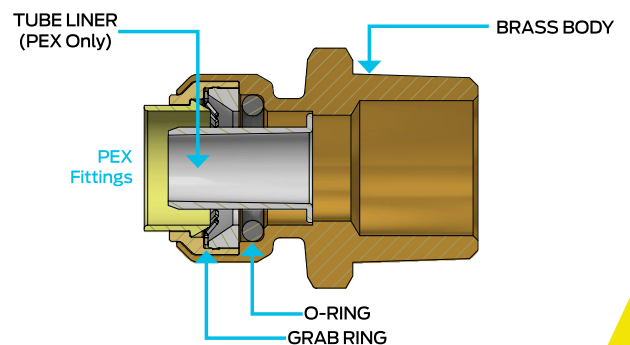

25 YEAR
GUARANTEE

All SharkBite® fittings are guaranteed against defects in materials or manufacturing for a period of 25 years from the date of purchase.

sharkbite.com.au | 1800 810 803 | sales.au@rwc.com

EPK0157_2025_v2

F3 Straight Male Connectors

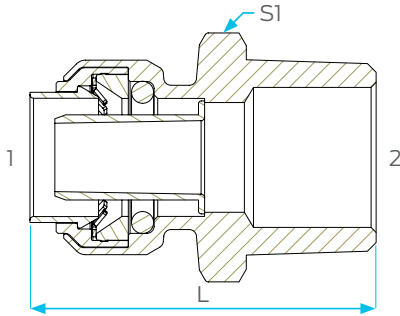

Product Dimensions

Code	1	2	L	S1
F116X	16 OD	R $\frac{3}{4}$ "-20	48	31.2
F120X	16 OD	R $\frac{1}{2}$ "-15	43	25.5
F134X	20 OD	R $\frac{3}{4}$ "-20	45	31.2
F138X	20 OD	R $\frac{1}{2}$ "-15	44	31.2
F140X	25 OD (Dn25Cu)	R1"-25	54	38.1
F142X	25 OD (DN25Cu)	R $\frac{3}{4}$ "-20	47	32.4

Note: All measurements in mm unless otherwise stated.

Working Pressures and Temperatures

Pipe	Pressure/Temperature
PEX SDR9	Designed for operating at 2000kPa / 20°C Max operating values of 1000kPa / 70°C

PEX Dimensions

Nominal Outside Diameter	16mm	20mm	25mm
Average Wall Thickness	2.15mm	2.45mm	3.00mm
Average Internal Diameter	11.7mm	15.2mm	19.1mm

Installation

Installation is subject to the requirements of the applicable regulatory authority, the National Construction Code Volume Three – Plumbing Code of Australia, associated reference standards as applicable at the time and AS/NZS 3500. This product is compliant to the Lead Free requirements of the National Construction Code Volume Three. For further Scope of Use, please visit www.rmc.com.au/resources.

Warranty

Reliance Worldwide Corporation (Aust.) Pty. Ltd. (RWC) will either replace or repair any defective goods where the defect arose as a result of manufacture within the warranty period. You may contact RWC at the phone number, address or e-mail shown below for further information or to make a claim.

Visit www.rmc.com.au/warranty to view the warranty statement in full and for further important information.

Standards and Approvals



AS/NZS 2537.2
WMKA 02056